

GEMStar XT ARR-RD003000 MULTI-TRAP System



The Arradiance MULTI-TRAP system is a high capacity, high conductance vacuum inlet trap that protects your Ebara EV-A10 pump against corrosive chemicals and abrasive particles. The system is configured to prevent both ALD induced particles and vapors from causing pump damage leaving a clean pump exhaust

- ◆ Engineered specifically for GEMStar XT and XT-P to minimize conductance loss
- ◆ Provides both stainless steel gauze and activated charcoal filters
- ◆ Allows filter replacement without the need to shut down the pump
- ◆ On board digital vacuum gauge for pump vacuum performance monitoring
- ◆ For more details on the trap see: <https://www.massvac.com/mv-multi-trap>

MULTI-TRAP for Ebara EV-A10 system Specifications

Compatibility	All XT System utilizing Ebara EV-A10 Dry pump
Pump Interface Port	NW-40
GEMStar XT Interface Port	NW-50
Particle Filter	Five (5) 4.5" SS Gauze
Vapor Filter	Five (5) 4.5" Activated Charcoal
Trap to pump shutoff valve	Manual NW-40 vacuum isolation
Digital Vacuum Gauge	1.0 x 10 ⁻⁴ to 1000 Torr convection gauge with internal controller and display
Particle Canister Material	316L SS
Seal Materials	Viton
Gauge Power Requirement (AC Adapter Supplied)	120V AC
Expected filter change requirement	>6 months
Pump Ebara EV-A10	Not Included

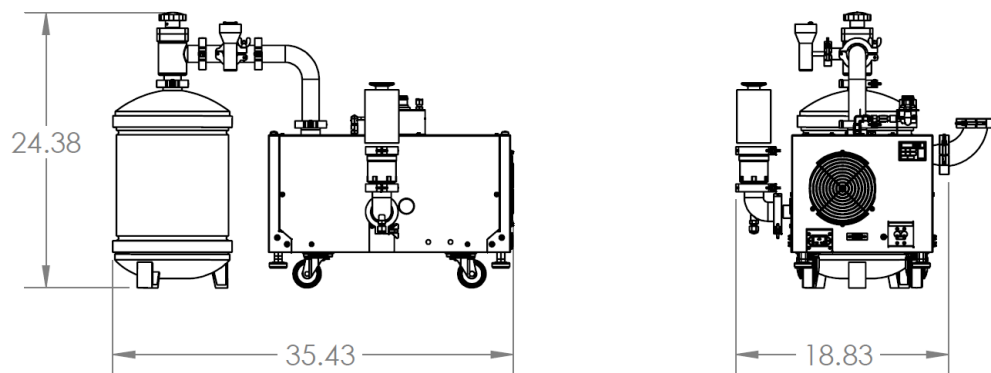

Above shown with Arradiance recommended EV-A10 dry pump (Dim in inches)
Pump sold separately

Molecular Innovation™